

Cutting device for rubber profiles

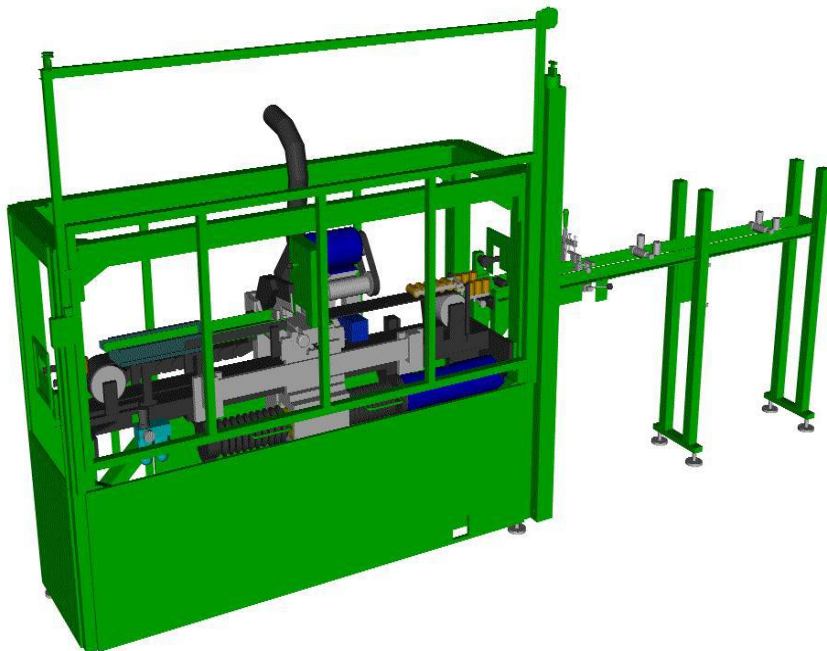

Utilization:

Cutting device is designed for the cutting of rubber profiles with or without metal reinforcement which drive out from the production line. Splitting is done without stopped material during the splitting operation. Profiles without metal reinforcement are cut by cutting. Profiles with metal reinforcement are cut by friction saw.

Technical description of device:

The material from the forming line enters the machine input module which is provided with supporting rollers and side rollers to prevent material deviation. Then the material progresses to a conveyor belt having the same speed as the material. The saw and the scissors are mounted on the crosspiece of conveyor. The movement of the friction saw into the cut is induced by pneumatic cylinders and the shearing of the scissors are induced also by pneumatic cylinders. After measuring the required length, the control system gives the command to start the engine of conveyor in the travel direction of the material. Movements of the mechanisms are automatically controlled by the control system. The split material is conveyed by the conveyor belt to the exit of the machine.

Basic technical specification:

Unput power:	8,38 kW
Power supply:	3NPE AC 50 Hz 400VTN-S
Minimum air pressure:	0,5 MPa
Material feed rate:	max. 30 m/min, min. 7 m/min
Minimum cut length:	700 mm at speed 30 m/min 400 mm at speed 30 m/min
Dimesions:	4730 x 800 x 1830 mm

Cutting device for rubber profiles

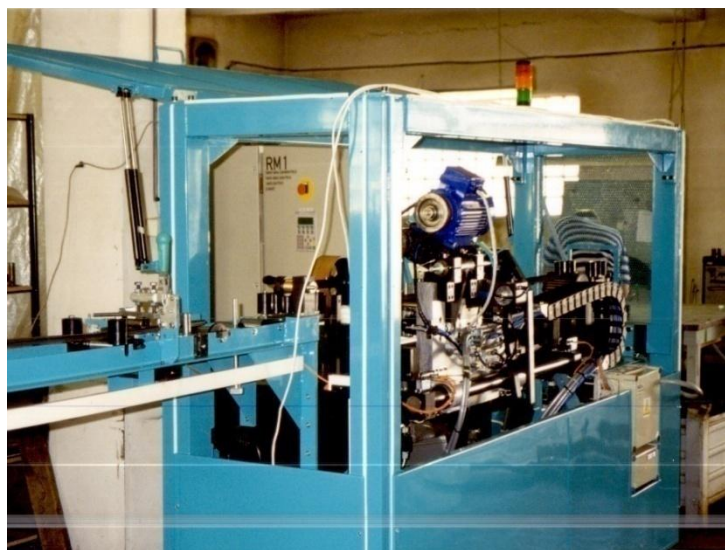
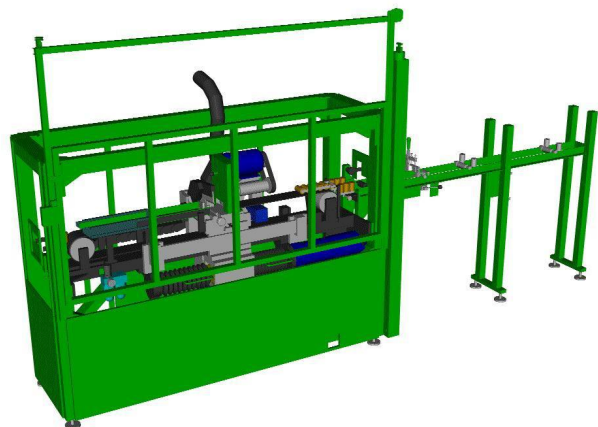

Realization:
DRAFTEX-OPTIMIT s.r.o.

1997

2 pc